



# HL TURN MARKER

The HL Compact LED drive light can be complemented by TYRI's LED turn signal, designed to work perfectly alongside the HL Compact to create an aesthetically pleasing design.

This marker light is approved to ECE regulation 6, Categories 1 & 6.



LED work lights are exposed to dirt, fertilizers, road salt, acids and more. For best performance and long lifetime, the lens and the cooling fins must be cleaned on a regular basis.

## TECHNICAL DATA

- Housing Material:** Cast Aluminium
- Mounting Options:** Flush
- Lens Material:** Amber PC
- Temperature range:** -40 to +85 °C
- Connector:** Deutsch (DT04-2P) with 350 mm harness.  
Mating part: DT06-2S
- Weight:** 150 g / 0,33 lb
- Light Patterns:** Indicator/Blinker

## FEATURES

- Overheating Protection
  - Over-voltage Protection
  - Polarity Protection
- Indicator/Blinker controlled by external relay.*

## TEST STANDARDS

- Salt Spray ASTM B117 500 h
- Vibration 5-2000 Hz 3 Axis, 10 Grms
- Shock Tested 50 G 11 ms
- IP69K
- R10 - EMC  
R6 - Direction indicator, Categories 1 & 6.

For further information visit [www.tyriLights.com](http://www.tyriLights.com) or contact your local sales team.

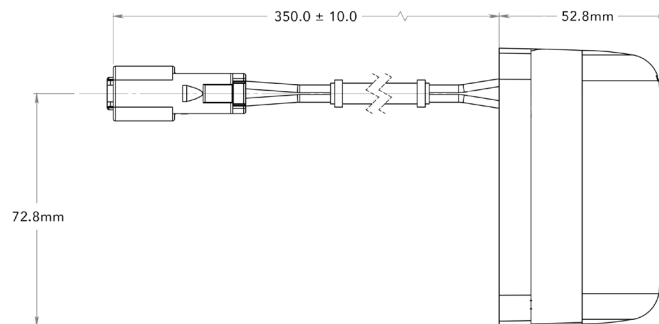
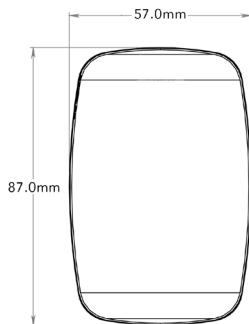

LIGHT FUNCTION	LIGHT OUTPUT	VOLTAGE		AMP DRAW		POWER	COLOR TEMP	LENS PATTERN	PART NO.	ECE
		Machine	Operating	12 V	24 V					
Indicator	NA	12-24 V	9-32 V	0,4 A	TBA	5 W	Amber			R6 & R10